



22146206

**DESIGN TECHNOLOGY
STANDARD LEVEL
PAPER 3**

Candidate session number

--	--	--	--	--	--	--	--	--	--

Tuesday 20 May 2014 (morning)

Examination code

1 hour

2	2	1	4	-	6	2	0	6
---	---	---	---	---	---	---	---	---

INSTRUCTIONS TO CANDIDATES

- Write your session number in the boxes above.
- Do not open this examination paper until instructed to do so.
- Answer all of the questions from one of the Options.
- Write your answers in the boxes provided.
- A calculator is required for this paper.
- The maximum mark for this examination paper is [30 marks].

Option	Questions
Option A — Food science and technology	1–6
Option B — Electronic product design	7–12
Option C — CAD/CAM	13–18
Option D — Textiles	19–24
Option E — Human factors design	25–30



36EP01

Option A — Food science and technology

- 1. Governments often provide advice on how to achieve healthier lifestyles. One current piece of UK government advice is that people should eat more fruit and vegetables.

Figure A1 shows the home page of a 5 A DAY online shopping list and menu planner from which consumers can access free advice. It also contains additional resources, such as recipes based on seasonal produce, and information about fruit and vegetables.

Figure A1: The 5 A DAY shopping list and menu planner

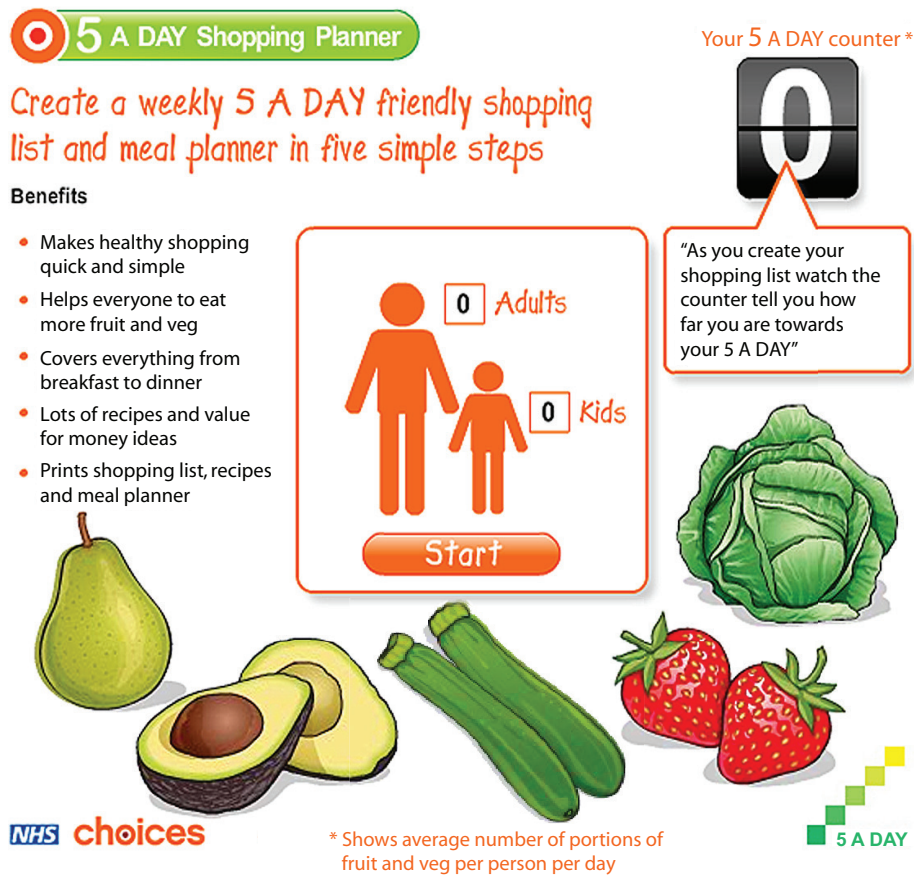

[Source: <http://www.nhs.uk/livewell/5aday/pages/portionsizes.aspx>.
Contains public sector information licensed under the Open Government Licence v2.0.]

- (a) State **one** health benefit of the 5 A DAY shopping list and menu planner for families with young children. [1]

.....

.....

(Option A continues on the following page)



(Option A, question 1 continued)

- (b) List **two** nutritional benefits of eating more fruit and vegetables. [2]

.....

- (c) Explain **one** reason why some governments provide public health advice and tools, such as the 5 A DAY shopping list and menu planner. [3]

.....
--

(Option A continues on the following page)



(Option A continued)

2. (a) Define *biological value*.

[1]

.....
.....

(b) Describe how low biological value foods are complemented in different parts of the world to ensure that amino acid requirements are met.

[2]

.....
.....
.....
.....

(Option A continues on the following page)



(Option A continued)

3. Browning of food occurs for different reasons. **Figure A2** shows bananas that have browned over time. **Figure A3** shows slices of bread that have been browned by toasting.

Figure A2: Browned banana



[Source: http://commons.wikimedia.org/wiki/File:Barangan_banana_Indonesia.JPG; author Midori]

Figure A3: Toasted bread

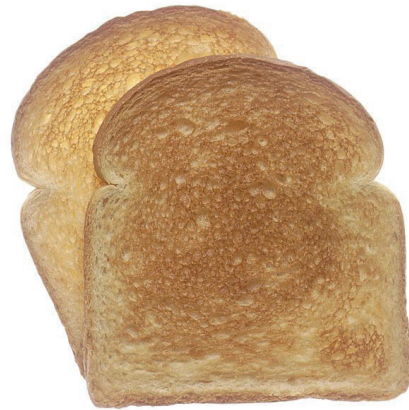

[Source: <http://commons.wikimedia.org/wiki/Toast#mediaviewer/File:ToastedWhiteBread.jpg>]

- (a) Describe how a banana browns over time.

[2]

.....
.....
.....
.....

- (b) Describe how the browning of the toasted bread occurs.

[2]

.....
.....
.....
.....

(Option A continues on the following page)



(Option A continued)

4. Outline **one** function of primary food packaging. [2]

.....
.....
.....
.....

5. Explain **two** ways in which the packaging of food products contributes to the development of brands. [6]

.....
.....
.....
.....
.....
.....
.....
.....
.....
.....
.....
.....

(Option A continues on the following page)



(Option A continued)

- 6. Explain **three** ways that the food industry in developed countries operates as a tightly-controlled just-in-time (JIT) system. [9]

.....

.....

.....

.....

.....

.....

.....

.....

.....

.....

.....

.....

.....

.....

.....

.....

.....

.....

.....

.....

.....

.....

.....

End of Option A



Turn over

Option B — Electronic product design

7. **Figure B1** shows a closed loop control system which can be used in a range of design contexts, for example, a climate control / air conditioning unit in a car. **Figure B2** shows the control panel for a climate control unit.

Figure B1: Closed loop control system

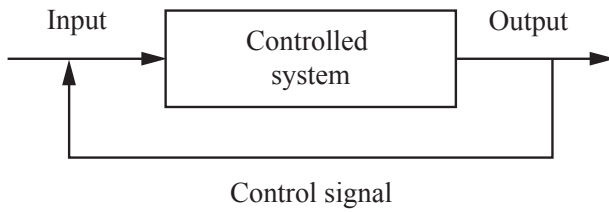

[Source: © International Baccalaureate Organization 2014]

Figure B2: The control panel for a climate control unit



[Source: www.preh.com]

- (a) State **one** piece of input data that is needed for the climate control unit to control the air temperature in a car. [1]

.....
.....

- (b) Outline **one** other variable that will impact on the effectiveness of the closed loop control system. [2]

.....
.....
.....
.....

(Option B continues on the following page)



(Option B, question 7 continued)

- (c) Explain why the closed loop control system for a car uses negative feedback. [3]

.....

.....

.....

.....

.....

.....

(Option B continues on the following page)



(Option B continued)

8. Figure B3 shows an operational amplifier circuit.

Figure B3: Amplifier circuit

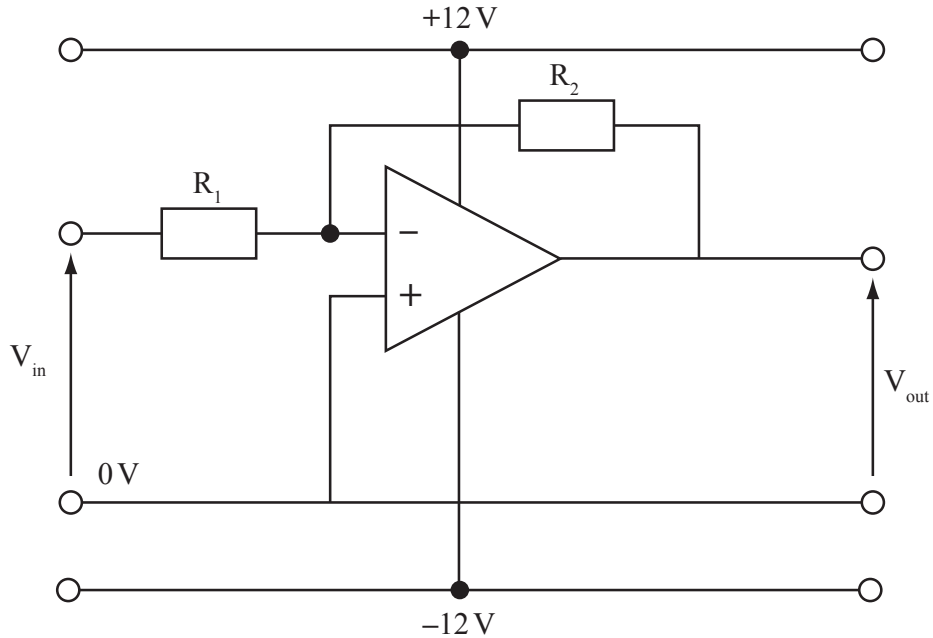

[Source: © International Baccalaureate Organization 2014]

(a) State the type of operational amplifier circuit shown in **Figure B3**. [1]

.....
.....

(b) Calculate the output voltage of the circuit V_{out} if R_1 equals $100\ \Omega$ and R_2 equals $50\ \Omega$. [2]

.....
.....
.....
.....

(Option B continues on page 12)



Please **do not** write on this page.

Answers written on this page
will not be marked.



36EP11

Turn over

(Option B continued from page 10)

9. **Figure B4** shows a screen shot of iTunes® – a generic digital music system.

Figure B4: iTunes®

Image removed due to copyright reasons
[Source: <http://www.apple.com/itunes/>]

(a) Outline **one** advantage for a consumer using a generic digital music system, such as iTunes®.

[2]

.....

.....

.....

.....

(Option B continues on the following page)



(Option B, question 9 continued)

(b) Outline **one** advantage for a manufacturer of developing its own digital music system. [2]

.....
.....
.....
.....

10. Describe using a diagram how the **NOT** function can be implemented using a **NOR** gate. [2]

(Option B continues on the following page)



(Option B continued)

11. Explain **two** reasons why many electronic products are designed to operate at dual voltages, for example, US 120 V UK 240 V. [6]

.....

.....

.....

.....

.....

.....

.....

.....

.....

.....

.....

.....

(Option B continues on the following page)



(Option B continued)

- 12.** Explain **three** advantages of using programmable interface controllers (PICs) when developing a hearing aid.

[9]

.....

.....

.....

.....

.....

.....

.....

.....

.....

.....

.....

.....

.....

.....

.....

.....

.....

.....

.....

.....

.....

.....

End of Option B



36EP15

Turn over

Option C — CAD/CAM

13. A toy company produced a number of physical models during the design development of its new toy car collection. **Figure C1** shows a CAD simulation of the production of a toy car. **Figure C2** shows a scale model of a toy car being machined from a block of metal on a five-axis computer numerical control (CNC) machine.

Figure C1: CAD simulation of a toy car

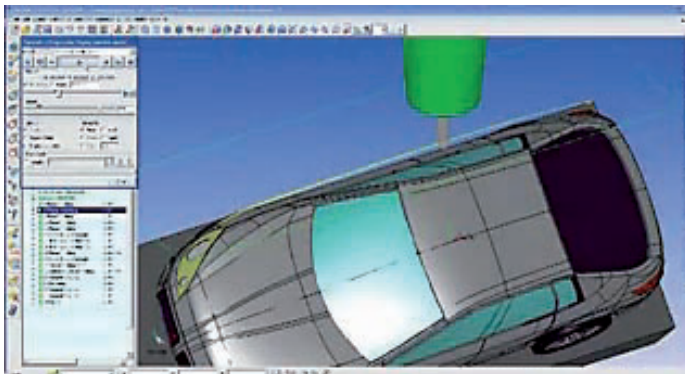

[Source: © Vero Software. Used with permission.]

Figure C2: Scale model of a toy car



[Source: © Vero Software. Used with permission.]

- (a) State **one** reason for using different feed speeds during the production of the scale model in **Figure C2**. [1]

.....
.....

- (b) Outline **one** advantage of using a five-axis CNC machine to produce the scale model in **Figure C2**. [2]

.....
.....
.....
.....

(Option C continues on the following page)



(Option C, question 13 continued)

- (c) Explain **one** benefit of creating the CAD simulation in **Figure C1** for the production of the scale model in **Figure C2**. [3]

.....

.....

.....

.....

.....

.....

(Option C continues on the following page)



(Option C continued)

- 14. Vehicle designers and engineers use motion capture technology in simulator laboratories to help optimize their designs, as shown in **Figure C3**.

Figure C3: Using motion capture technology in a simulator laboratory



[Source: <http://media.ford.com>. Ford Motor Company.]

- (a) Define *motion capture technology*.

[1]

.....
.....

- (b) Outline how motion capture technology assists in the design development of car interiors.

[2]

.....
.....
.....
.....

(Option C continues on the following page)



(Option C continued)

15. In rapid prototyping, 3D models are sliced into a number of 2D shapes. For optimal results, different orientations are considered. **Figure C4** and **Figure C5** show two different orientations for the same 3D model.

Figure C4: Orientation A

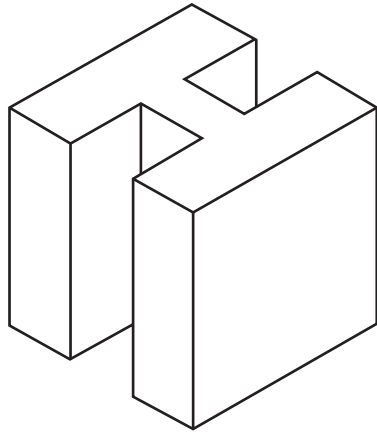
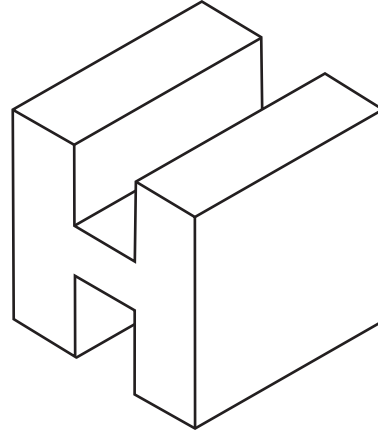

Figure C5: Orientation B



- (a) Outline **one** advantage of using orientation A (**Figure C4**) with solid object printing. [2]

.....
.....
.....
.....

- (b) Outline why either orientation A (**Figure C4**) or orientation B (**Figure C5**) is suitable for use with select laser sintering (SLS). [2]

.....
.....
.....
.....

(Option C continues on the following page)



(Option C continued)

16. Describe **one** health and safety issue related to using a laser cutter in industrial manufacturing. [2]

.....
.....
.....
.....

17. Explain **two** impacts of introducing computer numerically controlled (CNC) machines on the fixed and variable costs of a multinational company. [6]

.....
.....
.....
.....
.....
.....
.....
.....
.....
.....
.....
.....
.....
.....
.....

(Option C continues on the following page)



(Option C continued)

18. Discuss **three** issues when using natural timber to produce furniture with CNC equipment. [9]

.....

.....

.....

.....

.....

.....

.....

.....

.....

.....

.....

.....

.....

.....

.....

.....

.....

.....

.....

.....

.....

.....

.....

.....

.....

End of Option C



Turn over

Option D — Textiles

19. **Figure D1** shows the Nike® Flyknit shoe. The design brief was to produce a structurally supportive, lightweight, tight-fitting athletic shoe. It is made using polyester yarn with variable elasticity, durability, thickness, and strength. The Nike Flyknit shoe was designed for use by long-distance runners and was introduced to competition at the London 2012 Olympics.

Figure D1: The Nike® Flyknit shoe

Image removed due to copyright reasons

(Option D continues on the following page)



(Option D, question 19 continued)

- (a) State **one** characteristic relating to ease of maintenance that makes polyester suitable for the Nike Flyknit shoe. [1]

.....

.....

- (b) Outline **one** characteristic of knitted fabrics that contributes to the tight fit of the finished Nike Flyknit shoe. [2]

.....

.....

.....

.....

- (c) Explain the advantage to Nike of launching the Flyknit shoe at the London 2012 Olympics. [3]

.....

.....

.....

.....

.....

.....

(Option D continues on the following page)



36EP23

Turn over

(Option D continued)

20. (a) State **one** way that mass customization of textile products has enhanced consumer choice. [1]

.....
.....

(b) Outline **one** way in which CAD contributes to the mass customization of textile products. [2]

.....
.....
.....
.....

(Option D continues on the following page)



(Option D continued)

21. Figure D2 shows burrs which were the design inspiration of Velcro® (Figure D3).

Figure D2: Burrs



[Source: http://commons.wikimedia.org/wiki/File:Bur_Macro_BlackBg.jpg]

Figure D3: Velcro®

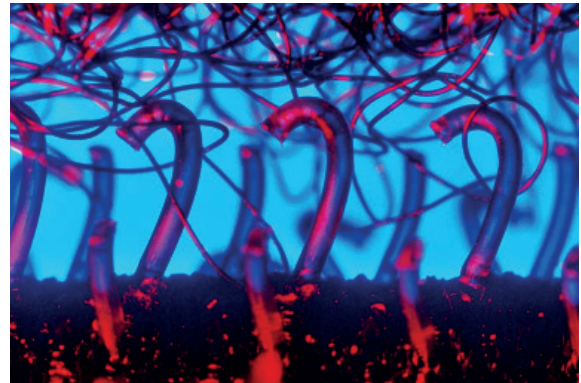

[Source: [http://commons.wikimedia.org/wiki/File:Micrograph_of_hook_and_loop_fastener,\(Velcro_like\).jpg](http://commons.wikimedia.org/wiki/File:Micrograph_of_hook_and_loop_fastener,(Velcro_like).jpg); Natural Philo]

(a) Outline **one** reason why Velcro is an example of biomimetics.

[2]

.....

.....

.....

.....

(b) Outline **one** reason why nylon is suitable for the production of Velcro.

[2]

.....

.....

.....

.....

(Option D continues on the following page)



36EP25

Turn over

(Option D continued)

22. Outline **one** way in which computer-aided manufacture (CAM) has contributed to the sustainability of the textile industry. [2]

.....

.....

.....

.....

23. Explain **two** considerations in relation to the biocompatibility of textile vascular prostheses. [6]

.....

.....

.....

.....

.....

.....

.....

.....

.....

.....

.....

.....

(Option D continues on the following page)



(Option D continued)

24. Explain **three** ways in which branding of textile products contributes to a global marketing strategy.

[9]

.....

.....

.....

.....

.....

.....

.....

.....

.....

.....

.....

.....

.....

.....

.....

.....

.....

.....

.....

.....

.....

End of Option D



Turn over

Option E — Human factors design

- 25. **Figure E1** shows a remote control handset used for use with a television set connected to a satellite receiver.

Figure E1: Remote control handset



[Source: Image courtesy of suphakit73/FreeDigitalPhotos.net]

- (a) State **one** reason why the control buttons on the handset are not all the same size. [1]

.....

.....

(Option E continues on the following page)



(Option E, question 25 continued)

(b) Outline **one** reason for the shape (profile) of the handset in **Figure E1**. [2]

.....

.....

.....

.....

(c) Explain **one** reason for using a colour scheme for the buttons on the handset shown in **Figure E1**. [3]

.....

.....

.....

.....

.....

.....

(Option E continues on the following page)



(Option E continued)

- 26. Mens' shirt sizes can be expressed in a number of ways, for example as small, medium or large or in terms of the collar size, generally expressed in inches. **Table E1** shows the expression of shirt sizes as small, medium, large (row 1) and collar sizes in inches (row 2).

Table E1: Alternative ways of expressing shirt sizes

Shirt size	S	M	L
Collar (inches)	14.5 and 15	15, 15.5 and 16	16.5 and 17

[Source: adapted from www.cottontraders.co.uk]

- (a) State the type of measurement scale used for shirt sizes in the first row of **Table E1**. [1]

.....

.....

- (b) Outline **one** reason why some manufacturers choose to produce shirts in the sizes small, medium and large. [2]

.....

.....

.....

.....

(Option E continues on the following page)



(Option E continued)

27. **Figure E2** shows a flow diagram identifying the stages in a human information-processing system. The flow diagram can be applied to the context of receiving and responding to a text message on a mobile phone.

Figure E2: Human information-processing system flow diagram

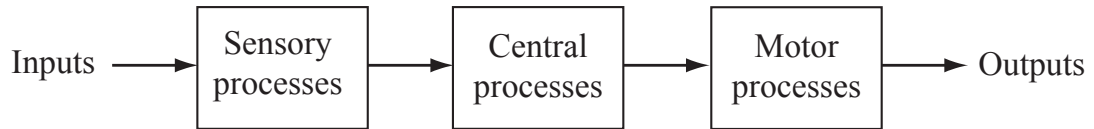

[Source: © International Baccalaureate Organization 2014]

(a) Describe the function of the sensory input when receiving a text message on a mobile phone. [2]

.....

.....

.....

.....

(b) Outline **one** reason why the motor processing stage may lead to errors in writing a response to the received message. [2]

.....

.....

.....

.....

(Option E continues on the following page)



(Option E continued)

28. Outline **one** reason why appearance prototypes are expensive to produce. *[2]*

.....

.....

.....

.....

29. Suggest **two** reasons why dimensions in anthropometric data tables are stated as estimates. *[6]*

.....

.....

.....

.....

.....

.....

.....

.....

.....

.....

.....

.....

.....

.....

.....

(Option E continues on the following page)



Please **do not** write on this page.

Answers written on this page
will not be marked.



36EP34

Please **do not** write on this page.

Answers written on this page
will not be marked.



36EP35

Please **do not** write on this page.

Answers written on this page
will not be marked.



36EP36